



## Submersible High Head Pump

711924 - BIA-B42A



# 1. Introduction

Congratulations on your purchase of a Bianco B42A Submersible Pump.

The B42A is a premium quality pump suitable for small to medium clean water, dewatering and or wastewater transfer applications the B42A holds AS/NZS4020 Drinking Water Approval. Paired with a suitable controller the B42A can be used as a pressure pump for potable water.

The B42A is designed specifically for AWTS (Aerated Water Treatment Systems) i.e., for discharging from Secondary Treatment septic tanks. The choice of materials and components make the B42A an excellent choice for OEM fitment and replacement of existing pumps.





# 2. Key Features

- Quality pump materials and construction to ensure reliable operation
- Glass Filled Nylon pump body and Stainless Steel motor cover
- Easy Grip, Nylon carry handle
- Triple Seal System: Dual mechanic Seal (Carbon Ceramic) in oil bath and Oil Seal
- 3 Stage, High Head pump with durable noryl impellers
- Elevated (88mm) suction intake with algae-resistant slotted strainer
- 10m Power lead and automatic Float Switch
- All Cables to H07RNF neoprene
- Automatic On/Off operation controlled by a flexible float
- Light weight







# 3. Contents

<b>1. Introduction .....</b>	<b>2</b>
<b>2. Key Features.....</b>	<b>2</b>
<b>3. Contents.....</b>	<b>2</b>
<b>4. ISO 7010 Symbols used in this manual .....</b>	<b>3</b>
<b>5. Warnings.....</b>	<b>3</b>
<b>6. Cautions .....</b>	<b>4</b>
<b>7. Technical Specifications.....</b>	<b>4</b>
<b>8. Electrical Connections .....</b>	<b>6</b>
<b>9. Installation &amp; Operating Instructions.....</b>	<b>6</b>
<b>10. Replacement pump in an AWTS system .....</b>	<b>7</b>
<b>11. Trouble Shooting Guide.....</b>	<b>7</b>
<b>12. Warranties – Terms and Conditions.....</b>	<b>8</b>

## 4. ISO 7010 Symbols used in this manual

	Warning - Electrical safety
	Warning – Potential consequences of use outside of intended application(s). Includes environmental condition warnings.
	Mandatory warning
	Warning to disconnect power
	Read carefully

## 5. Warnings

	Read the manual carefully before starting
	Prior to starting installation or any maintenance the pump must be disconnected from the power supply and pressure relieved from the system including controller, pump and associated pipework.
	A qualified electrician should correctly size and install circuit breakers to protect the power supply. The fitment of additional surge protection is recommended.
	Any changes or modification to the wiring must be carried out by suitably qualified personnel.
	This appliance is not intended for use by persons (including children) with reduced physical, sensory or mental capabilities, or lack of experience and knowledge, unless they have been given supervision or instruction concerning use of the appliance by a person responsible for their safety. Children should be supervised to ensure that they do not play with the appliance.
	To avoid excessive thermal shock to the motor, the pump should not start more than 20 times in any one-hour period. The pump relies on pit water for cooling and should not operate partially submerged for longer than 10 minutes. Sustained operation at high head/low flow will result in overheating and compromise pump life expectancy
	Ensure that the installation will comply with all applicable local regulations.

## 6. Cautions

The pump relies on pit water for cooling and should not operate partially submerged for longer than 10 minutes. Sustained operation at high head/low flow will result in overheating and compromise the pump life expectancy

Running the pump without water or allowing the pump to run dry will damage the mechanical seal and void the warranty.

Avoid situations where the pump could be exposed to corrosive liquids or gasses, or to flammable materials, solvents etc.

Fitment and replacement must be carried out by competent, skilled, qualified personnel.

## 7. Technical Specifications

	Part #	kW	Amps	Volts	Max Head	Max Flow	Max Solids	Outlet
<b>BIA-B42A</b>	711924	0.55	4.0	240	32m	105 lpm	3mm	1" BSPF

Dimensions:

Height 470mm

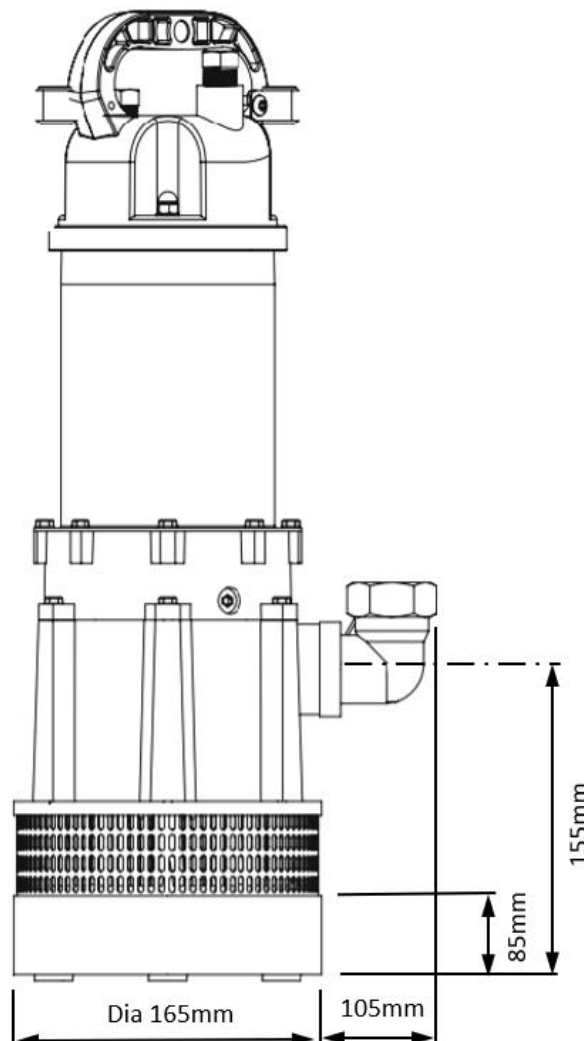



## 8. Electrical Connections

Voltage: 240V 50Hz Single Phase, +10 / -5%, DOL connection

### WARNINGS:

- All electrical work must be performed by an authorized electrician, in compliance with Au/NZ Wiring Regulations. Never allow an unauthorized person to perform electrical work.
- Improper wiring can lead to current leakage, electrocution, fire or pump failure.
- A power point (10amp) should be provided by a qualified electrician in compliance with the requirements of AS/NZS 3000.



Always use an electrical outlet protected by Residual Current Device (RCD) Safety Switch with a trip current of 30mA or less. A Safety Switch is required by Au/NZ Standard **AU/NZS 60335.1-2011**.

The pump is supplied with a 10 amp rated lead and AS/NZ 3112 (Type 1) 3 pin male power plug for connecting to mains power.

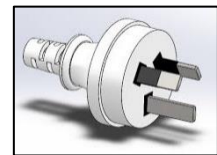

Exercise care with the power cord. Route the cord carefully to avoid potential snagging or chafing hazards.



Never lift the pump by the power cord or disconnect from the power supply by pulling the cord.

## 9. Installation & Operating Instructions

**Pumps should never be used to pump flammable or corrosive fluids.**

### Installation

The Bianco B42A pump should be installed on a level surface in a stationary position connected to fixed pipe work. Flexible pipe can only be used if no blockages or kinks are ensured.

A rope or lifting chain must be attached to the handle of the pump at the time of installation. **Never remove or lift a pump by its power cable.**

Automatic pumps with a float switch should be installed in a sump or pit of suitable size for the float switch to operate correctly. The float switch must not touch the base of the sump or pit which could prevent the pump from switching off and causing it to run dry.

**The float switch must be installed so the ON and OFF operating points can be easily reached i.e. the float switch head must not be too close to the latching holder (approx. 100mm of cable between latching holder and float head).**

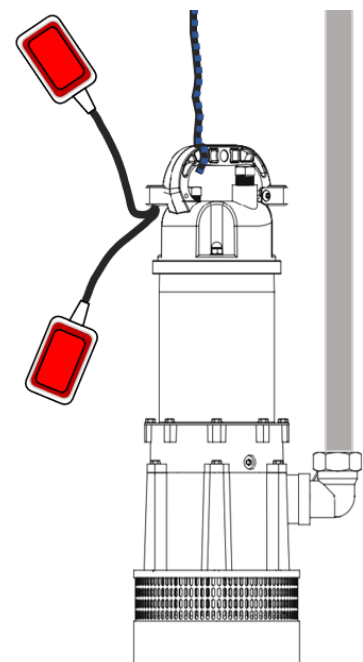

All single phase models have automatic reset thermal overload protection built in. This thermal overload will switch the motor off in an overload/overtemperature situation and will automatically reset when the motor has cooled down.

If the supply cord is damaged, the pump should be returned to White International or one of our Authorised Service Agents for repair in order to avoid potential injury/electrical shock.

## 10. Replacement pump in an AWTS system

When replacing the pump in an AWTS system it is strongly recommended to perform a volumetric pump-down test OR to fit a pressure gauge to the discharge piping to assess the condition of the dispersal field.

**Sustained operation at high head/low flow will result in overheating and compromise the pump life expectancy**

## 11. Trouble Shooting Guide

Fault	Cause	Remedy
Pump does not start	No mains supply	Check that power is available at the power socket and that it is switched on
	Blown fuse or tripped breaker	Replace fuse or reset breaker
	Impeller jammed	Disconnect power and clean impeller
	Thermal overload has been activated	Allow the switch to reset itself
	Float switch is in the down/off position	Free the float switch and change the position of the pump to prevent this in future
	Insufficient water level	Float switch must be in the up/on position (45° above horizontal)
No or low flow	Strainer or impeller blocked by debris	Disconnect from power and clean impeller area
	Damage caused by abrasive media	Pump may need to be serviced to replace worn parts
	Excessive friction loss or high delivery head	Reassess if the pipe size and pump is suitable for the application
Pump does not stop	Float switch is in the up/on position	Free the float switch and change the position of the pump to prevent this in future
	Possible faulty float switch	Pump may need to be serviced to replace faulty part
Pump switches off after short period	Thermal overload has been activated	Disconnect power and make sure impeller is not clogged
		Ensure water temperature is below 40°
		Check the length of the power supply cable/extension. Possible voltage drop over long distances.
		Ensure the pump is not operating at a very low flow or very high head.

## 12. Warranties – Terms and Conditions

This warranty is given in addition to the consumer guarantees found within the Australian Competition and Consumer Act 2010 (Cth) for goods purchased in Australia and the Consumer Guarantees Act 1993 NZ for goods purchased in New Zealand:



1) White International Pty Ltd / White International NZ Ltd (White International) warrant that all products distributed are free from defects in workmanship and materials, for their provided warranty period as indicated on the top or opposite side of this document. Subject to the conditions of the warranty, White International will repair any defective products free of charge at the premises of our authorised service agents throughout Australia and New Zealand if a defect in the product appears during the warranty period. If you believe that you have purchased a defective product and wish to make a claim under this warranty, contact us on our Sales Hotline on 1300 783 601, or send your claim to our postal address or fax line below and we will advise you as to how next to proceed. You will be required to supply a copy of your proof of purchase to make a claim under this warranty.

2) This warranty excludes transportation costs to and from White International or its appointed service agents and excludes defects due to non-compliance with installation instructions, neglect or misuse, inadequate protection against the elements, low voltage or use or operation for purposes other than those for which they were designed. For further information regarding the suitability of your intended application contact us on our Sales Hotline on 1300 783 601. If you make an invalid claim under this warranty, the original product will be sent back to you unrepai red.

3) This warranty refers only to products sold after the 1st January 2012, and is not transferable to another product type and only applies to the original owner, purchaser or end user, and is in addition to the consumer guarantees found within the Competition and Consumer Act 2010 (Cth) for goods purchased in Australia and the Consumer Guarantees Act 1993 (NZ) for goods purchased in New Zealand.

4) Our goods come with guarantees that cannot be excluded under the Australian Consumer Law. You are entitled to a replacement or refund for a major failure and for compensation for any other reasonably foreseeable loss or damage. You are also entitled to have the goods repaired or replaced if the goods fail to be of acceptable quality and the failure does not amount to a major failure. 2 YEAR WARRANTY.

5) To the fullest extent permitted by law, White International excludes its liability for all other conditions or warranties which would or might otherwise be implied at law. To the fullest extent permitted by law, White International's liability under this warranty and any other conditions, guarantees or warranties at law that cannot be excluded, including those in the Competition and Consumer Act 2010 (Cth), is expressly limited to: (a) in the case of products, the replacement of the product or the supply of equivalent product, the payment of the cost of replacing the product or of acquiring an equivalent product or the repair of the product or payment of the cost of having the product repaired, is at the discretion of White International or a 3rd party tribunal elected under the Competition and Consumer Act 2010 (Cth) for goods purchased in Australia and the Consumer Guarantees Act 1993 (NZ) for goods purchased in New Zealand; and

6) To the fullest extent permitted by law, this warranty supersedes all other warranties attached to the product or its packaging.

7) In the case of services, supplying the services again or the payment of the cost of having the services supplied again, is at the discretion of White International or a 3rd party tribunal elected under the Competition and Consumer Act 2010 (Cth) for goods purchased in Australia and the Consumer Guarantees Act 1993 (NZ) for goods purchased in New Zealand. 8) Our warranty commences from the date of purchase of the above mentioned pumps. Proof of purchase is required before consideration under warranty is given.

*Record your date of purchase in the space below and retain this copy for your records.*

**Date of Purchase** .....**Model Purchased** .....





**[www.whiteint.com.au](http://www.whiteint.com.au)**

**[www.whiteint.co.nz](http://www.whiteint.co.nz)**

**Please always refer to our website for further technical information & new product innovations**

**Disclaimer:** Every effort has been made to publish the correct information in this manual. No responsibility will be taken for errors, omissions or changes in product specifications.

© 2023 Copyright White International Pty Ltd

TM ® - WARNING: Please be aware that various brands & products depicted within this document are subject to trademark, patent or design registrations. Infringement of any intellectual property contained within this document without express written authority by the appropriate intellectual property holder may result in further legal action to be taken. For any queries regarding use of the contained information please feel free to contact White International Pty Ltd.